

## **Installation Manual**

Please read this manual carefully before installing and using the modules.

In order to enable the PV module to be installed correctly and to generate electric power properly, please read the following operation instruction carefully.

### **I 、 Warning:**

1. Artificially concentrated sunlight shall not be directed on the module or panel.
2. Application class is class A.
3. Fire resistant roof covering is Class C.
4. Modules rated for use in this application class may be used in systems operating at greater than 50V DC or 240W, where general contact access is anticipated. Modules qualified for safety through this part of IEC61730 and IEC61730-2 and within this application class are considered to meet the requirements for safety class II.
5. Under normal conditions, a photovoltaic module is likely to experience conditions that produce more current and/or voltage than reported at standard test conditions. Accordingly, the value of  $I_{sc}$  and  $V_{oc}$  marked on this module should be multiplied by of 1.25 when determining component voltage ratings, conductor current ratings, fuse sizes, and size of controls connected to the PV output.
6. Do not touch live terminals with bare hands. Use insulated tools for electrical connections.
7. To reduce the risk of electrical shock or burns, modules may be covered with an opaque material during installation to avoid shocks or burns.
8. The installation work of the PV array can only be done under the protection of sun-sheltering covers or sunshades and only qualified person can install or perform maintenance work on this module.
9. Follow the battery manufacture's recommendations if batteries are used with

modules.

10. The modules have been evaluated by TUV for a maximum positive or negative design loading of 5400 Pa.

11. All instructions should be read and understood before attempting to install, wire, operate and maintain the module.

12. If instructions are provided allowing modules to be installed in parallel electrically, the installation instructions shall specify that each module (or series string of modules so connected) shall be provided with the maximum series fuse.

## **II 、 Unpacking**

After the PV module has been shipped to the installation site all of the parts should be unpacked properly with care.

Caution: The condign environment for unpacking the modules and all other apparatus should be proofed against dampness and rainfall.

### III、Characteristics

#### 1. JTM175-72M Series Electrical Characteristics:

Model		JTM160-72M	JTM165-72M	JTM170-72M	JTM175-72M	JTM180-72M	JTM185-72M	JTM190-72M
		Parameter						
Peak power	Pm (W)	160	165	170	175	180	185	190
Maximum operating Voltage	Vmp (V)	35.0	35.0	35.5	35.5	36.0	36.0	36.0
Maximum operating Current	Imp (A)	4.57	4.71	4.79	4.93	5.0	5.14	5.28
Short Circuit Current	Isc (A)	5.12	5.28	5.36	5.52	5.6	5.76	5.91
Open Circuit Voltage	Voc (V)	42.0	42.0	42.6	42.6	43.2	43.2	43.2
Maximum System Voltage	(VDC)	1000						
Power Tolerance	(%)	±5%						

Standard Test Condition: Tc=25°C, AM=1.5, E=1000W/m<sup>2</sup>

Each module (or series string of modules so connected) shall be provided with the maximum series fuse as specified, the maximum series fuse is 10A.

STRUCTURE:

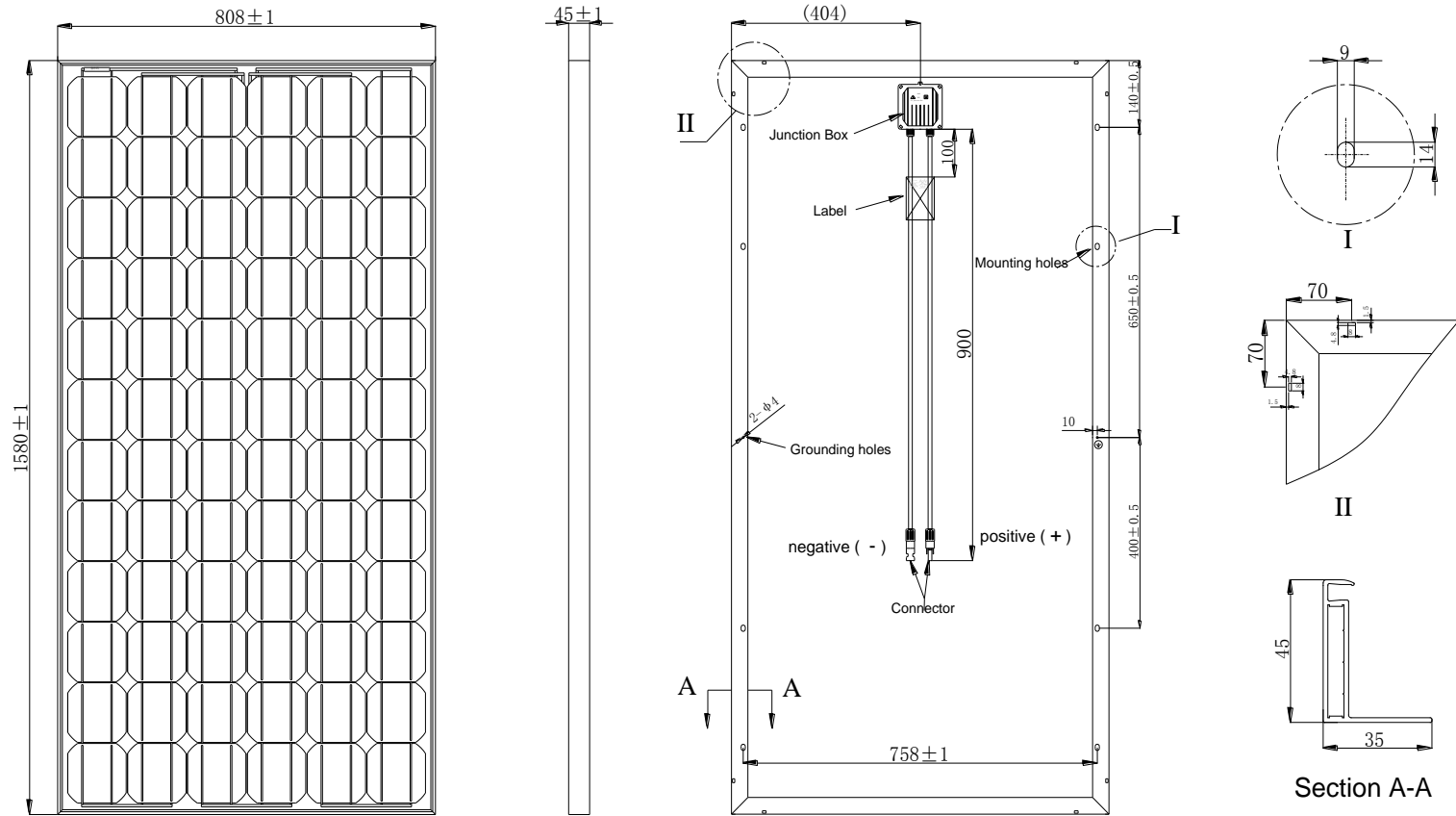

Zhejiang Jiutai New Energy Co., Ltd.

2. JTM220-96M Series Electrical Characteristics:

Model		JTM200-9	JTM205-9	JTM210-9	JTM215-9	JTM220-9	JTM225-9	JTM230-9	JTM235-9	JTM240-9
		6M	6M	6M	6M	6M	6M	6M	6M	6M
Peak power	Pm (W)	200	205	210	215	220	225	230	235	240
Maximum operating Voltage	Vmp (V)	46	46.5	47	47.5	48	48	48	48	48
Maximum operating Current	Imp (A)	4.34	4.41	4.47	4.53	4.58	4.69	4.79	4.89	5
Short Circuit Current	Isc (A)	4.86	4.94	5.01	5.07	5.13	5.25	5.36	5.48	5.60
Open Circuit Voltage	Voc (V)	55.2	55.8	56.4	57	57.6	57.6	57.6	57.6	57.6
Maximum System Voltage	(VDC)	1000								
Power Tolerance	(%)	±5%								

Standard Test Condition: Tc=25°C, AM=1.5, E=1000W/m<sup>2</sup>

Each module (or series string of modules so connected) shall be provided with the maximum series fuse as specified, the maximum series fuse is 10A.

STRUCTURE:

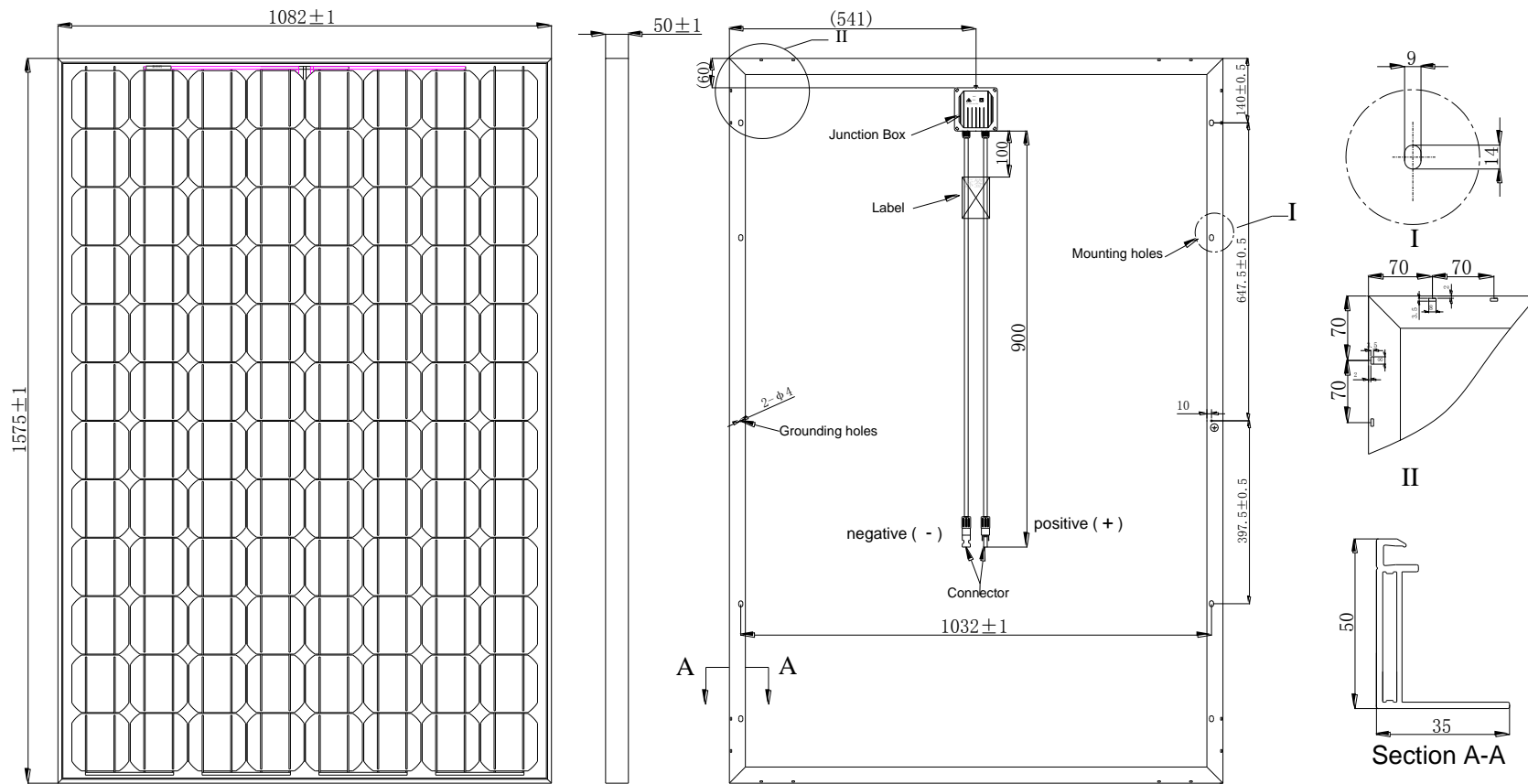

Zhejiang Jiutai New Energy Co., Ltd.

3. JTM220-60P Series Electrical Characteristics:

Parameter		Model								
		JTM200-60P	JTM205-60P	JTM210-60P	JTM215-60P	JTM220-60P	JTM225-60P	JTM230-60P	JTM235-60P	JTM240-60P
Peak power	Pm (W)	200	205	210	215	220	225	230	235	240
Maximum operating Voltage	Vmp (V)	28.5	28.5	29.0	29.0	29.5	29.5	30.0	30.0	30.0
Maximum operating Current	I <sub>mp</sub> (A)	7.02	7.19	7.24	7.41	7.46	7.63	7.67	7.83	8.0
Short Circuit Current	I <sub>sc</sub> (A)	7.86	8.05	8.11	8.30	8.36	8.55	8.59	8.77	8.96
Open Circuit Voltage	V <sub>oc</sub> (V)	34.2	34.2	34.8	34.8	35.4	35.4	36.0	36.0	36.0
Maximum System Voltage	(VDC)	1000								
Power Tolerance	(%)	±5%								

Standard Test Condition: T<sub>c</sub>=25 °C, AM=1.5, E=1000W/m<sup>2</sup>

Each module (or series string of modules so connected) shall be provided with the maximum series fuse as specified, the maximum series fuse is 15A.

STRUCTURE:

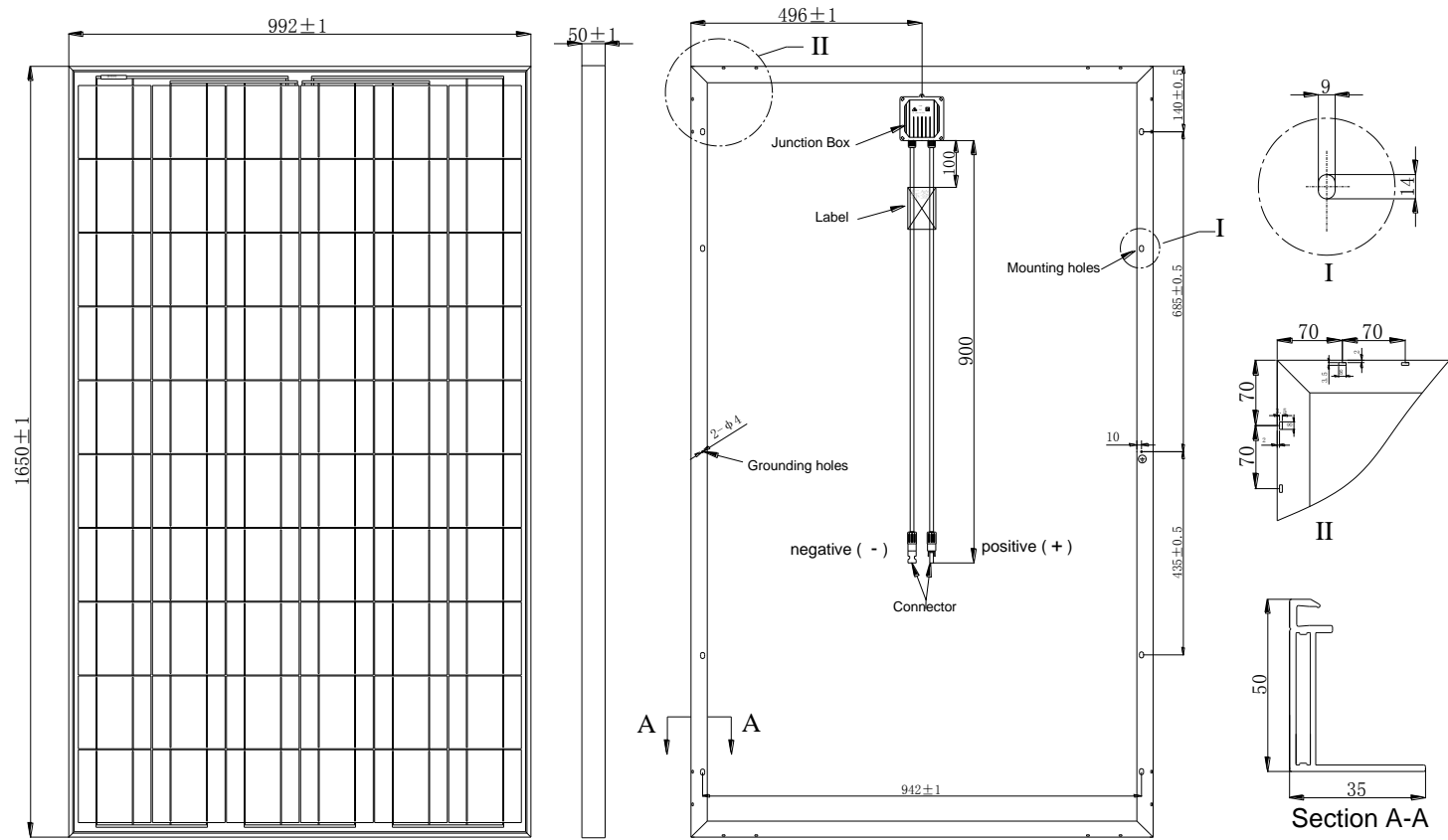



#### **IV、 Preparation before Installation:**

1. Optical check before installation, to make sure there is no bug in the packing and junction box as well as the surface of module.
2. Check the series number
3. Check the solar cell modules with irradiance of more than  $600\text{W}/\text{m}^2$  and get the voltage. In case the voltage is ZERO, it should NOT be installed and please contact the supplier.
4. Tools & Material for Installation

① Screwdriver

② Clamp

③ Each mounting hole matches with a set of a screw, nut and washer, quantity and type are as below:

NO.	description	type	quantity	Material	remark
1	bolt	M8*20mm	8	Stainless steel	
2	Nut	M8	8	Stainless steel	
3	washer	8mm	8	Stainless steel	

④ The users should design and build metallic bracket for installing and bearing the weight of the PV modules. The brackets are specially designed for users' installation places such as the open land or on the roof of houses.

Caution: To avoid damage from flooding and other unpredictable events, and avoid heavy impact. To design a gradient angle facing the sun radiation direction in order to insure the full sunshine receives as much as possible.

#### **V、 Installation and Operation**

1. Systems should be installed by qualified personnel only and at least two persons. The system involves electricity, and can be dangerous if the personnel are not familiar with the appropriate safety procedures.

2. Do not step on the module.
3. Although modules are quite rugged, the glass can be broken (and the module will no longer work properly) if it is dropped or hit by tools or other objects.
4. Put the solar cell modules on the frame and put on the screws and then combine them firmly after put on all the washers. All the screw caps should be finished on the frame together firmly. The module frame is made of anodized aluminum, and therefore corrosion can occur if the module is subject to a salt-water environment with contact to a rack of another type of metal. (Electrolysis Corrosion) if required. PVC or stainless steel washers can be placed between the solar module frame and support structure to prevent this corrosion.
5. The solar module frame must be attached to a support structure using M8 stainless steel hardware of eight (8) places symmetrical on the solar module. The stainless steel hardware used for securing the module frame should secure with an applied torque of 6 foot-pounds (8 Newton-meters).  
The recommended standoff height is 20 cm. If other mounting means are employed this may affect the TUV Listing or the fire class ratings, the incline angle  $\alpha$  to be adjusted according to local condition.

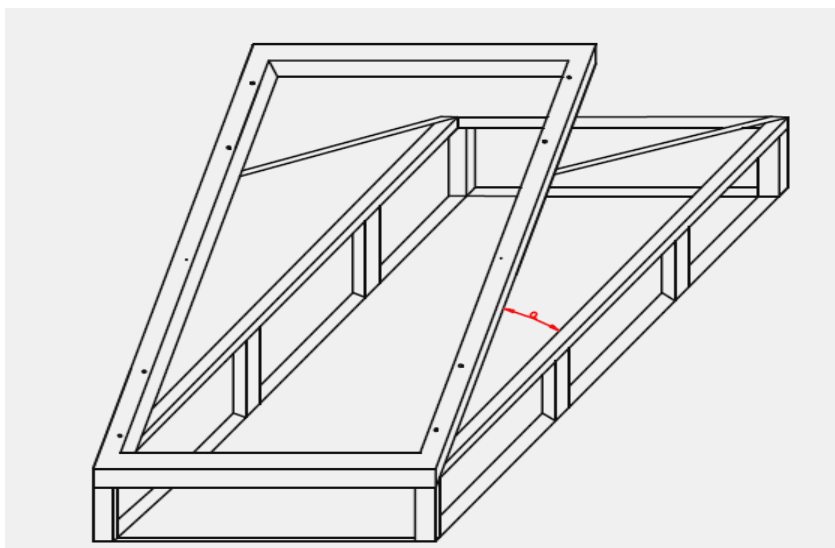

The module have been evaluated by TUV for mounting using the 8 provided mounting holes in the frame.

#### 6. Way of grounding:

All module frames should be grounded for safety. The grounding connections between modules must be approved by a qualified electrician, the grounding itself must be made by a qualified electrician. The ground wire should be at least the same size as the electrical conductors, ground wires no less than 12AWG are recommended.

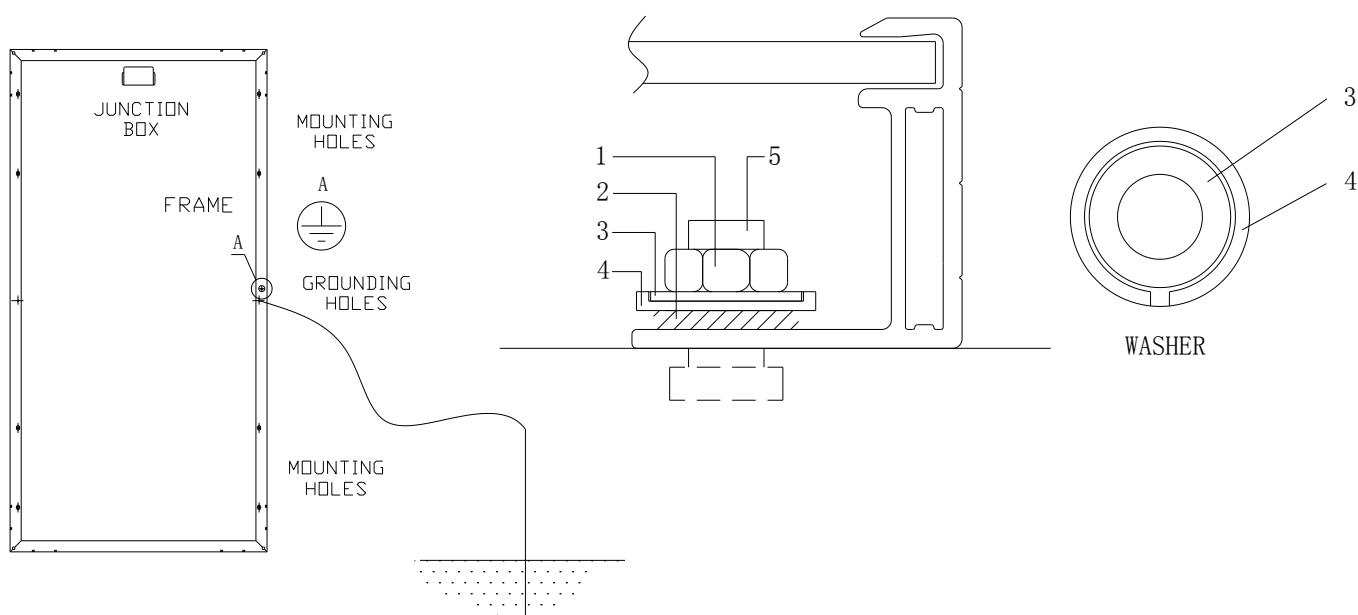

1. Stainless steel M8 nut
2. Stainless steel serrated washer
3. Stainless steel washer
4. Stainless steel cupped-shape washer
5. Stainless steel M8 t-head bolt

7. Module support structures that are to be used to support modules should be wind rated and approved for use by the appropriate local and civil codes prior to installation.

8. When solar modules are used to charge batteries, the battery must be installed

in a manner, which will protect the performance of the system and the safety of its users. Follow the battery manufacturer's guidelines concerning installation, operation and maintenance recommendations. In general, the battery (or battery bank) should be away from the main flow of people and animal traffic. Select a battery site that is protected from sunlight, rain, snow, debris, and is well ventilated. Most batteries generate hydrogen gas when charging, which can be explosive. Do not light matches or create sparks near the battery bank. When a battery is installed outdoors, it should be placed in an insulated and ventilated battery case specifically designed for the purpose.

9. In most applications, PV modules should be installed in a location where they will receive maximum sunlight throughout the year. In the Northern Hemisphere, the modules should typically face south, and in the Southern Hemisphere, the modules should typically face north. Modules facing 30 degrees away from true South (or north) will lose approximately 10 to 15 percent of their power output. If the module faces 60 degrees away from true South (or North), the power loss will be 20 to 30 percent. When choosing a site, avoid trees, buildings or obstructions, which could cast shadows on the solar.

## **VI、 Wiring and Connection:**

1. Before this procedure, please read the operation instructions of the PV control system carefully.
2. The cable diameter is  $4\text{mm}^2$ , type is PV1-F,  $1*4.0\text{mm}^2$ . Max. Temperature at conductor is  $120^\circ\text{C}$ , Ambient Temperature is  $-40^\circ\text{C} \sim +90^\circ\text{C}$ . Manufacturer is Cixi Renhe Photovoltaic Electrical Appliance Co., Ltd.
3. The connector type is **05-1**. Ambient Temperature is  $-40^\circ\text{C} \sim +85^\circ\text{C}$ . Manufacturer is Cixi Renhe Photovoltaic Electrical Appliance Co., Ltd.

4. The bypass diode type is 10SQ050, Manufacturer is Yangzhou Yangjie Electronic Technology Co., Ltd.

Partial shading of an individual module can cause a reverse voltage across the shaded module. Current is then forced through the shaded area by the other modules.

When a bypass diode is wired in parallel with the series string, the forced current will flow through the diode and bypass the shaded module, thereby minimize module heating and array current losses. Diodes are used as bypass diodes.

Have a Rated Average Forward Current 10A .Above maximum system current at highest module operating temperature.

Have a Rated Repetitive Peak Reverse Voltage 50V. Above maximum system voltage at lowest module operating temperature.

5. When designing the system, we recommend that the maximum number of modules in parallel should be no more than four while the maximum number of modules in series no more than eight.

6. Make wiring by Multi-connecting cables between the PV modules in series or parallel connection, which is determined by user's configuration requirement for system power, current and voltage.

7. Open the connection box of the control system and connect the cabled from the PV arrays to the connection box in accordance with the installation indication of the PV control systems.

8. All module frames and mounting racks must be properly grounded in accordance with local and national electrical codes.

9. Follow the requirements of applicable local and national electrical codes.

## **VII、Maintenance and Care:**

Zhejiang Jiutai New Energy Co., Ltd.

---

1. A built up of dust or dirt on the module(s) front face will result in a decreased energy output. Clean the panel(s) preferably once per annum if possible (dependant on site conditions) using a soft cloth dry or damp, as necessary.
2. Never use abrasive material under any circumstances.
3. Examine the PV module(s) for signs of deterioration. Check all wiring for possible rodent damage, weathering and that all connections are tight and corrosion free. Check electrical leakage to ground.
4. Check fixing screws and mounting brackets are tight, adjust and tighten as necessary.

It is the great honor to provide you with our PV modules.

Zhejiang Jiutai New Energy Co., Ltd.

No. 9 Huangwan Industrial Park Haining ,Zhejiang province ,P.R.C

TEL: +86-573-87953922

FAX: +86-573-87953933